

2020

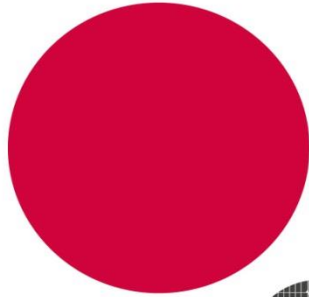

Simply smarter in modules.

energetica

Up to 50 degrees cooler
High power modules with intelligent electronics

Rene Battistutti, CEO
PV Magazine Spotlight | September 16, 2020

AGENDA

- 
- e Who we are and what guides us
 - e Current technology
 - e e.ISP intelligent technology
 - e Energetica product families

PHOTOVOLTAIC EXCELLENCE MADE IN AUSTRIA.

Who we are and what guides us

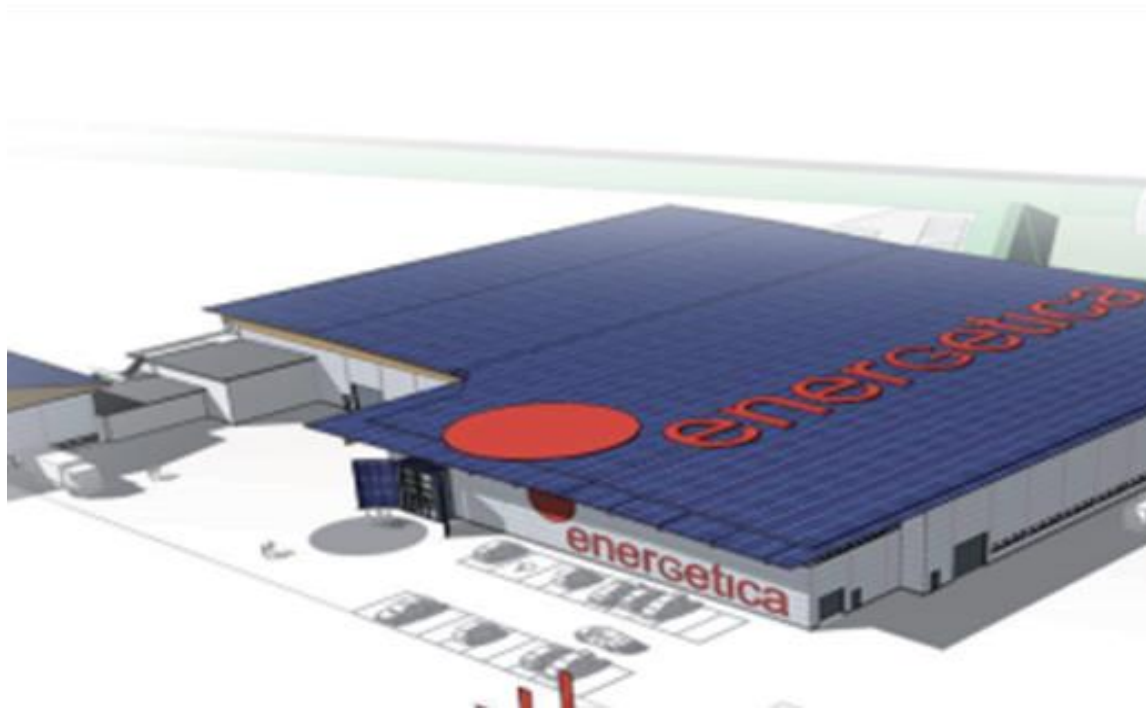

Energetica Industries GmbH produces photovoltaic modules on an industrial level and is the technology leader in Europe.

The new facility in Liebenfels/Austria operates according to most modern Industry 4.0 standards.

Our vision and philosophy is to consider the environmental impact in everything the company does and to minimize CO2 emissions.

The production is climate neutral. The energy required for ongoing operations is generated on site.

Whole facility is powered by a 2.7 MWp PV power plant built with our modules.

The factory building is made of wood. The entire vehicle fleet consists of Tesla electric cars.

CURRENT TECHNOLOGY.

Bypass diodes dominated the past decades

Actually worldwide 620 GWp of PV-Modules installed

- e approx. 2,7 billion pv-modules
- e approx. 160 billions solar cells
- e approx. 970 billions solder joints
- e approx. **8 billions of bypass diodes**

Out of that the international studies show that

- e there are failures with opened Bypass-Diodes
- e there are failures with shorted Bypass-Diodes
- e there are „partially damaged“ Bypass-Diodes

Bypass diodes have been widely utilized in crystalline silicon (c-Si) photovoltaic (PV) modules to maximize the output of a PV module array under partially shaded conditions.

Source : Fraunhofer ISE, Heribert Schmidt, Vortrag auf dem 31 Symposium Photovoltaische Solarenergie 2016, Aktive Bypass-Dioden Aktuelle Technik, Anwendungsgebiete und Markt.



WHY A BYPASS IS NEEDED IN PV MODULES ?

Bypass diodes dominated the past decades

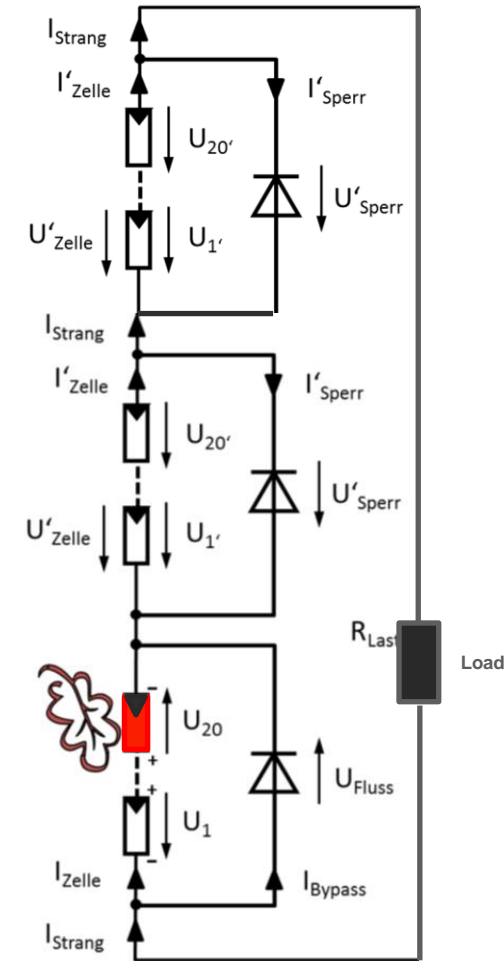

- e solar cell protection**
 protection from Hot Spots of the single solar cells due to high reverse voltages in case of in case of shading
- e fire safety**
 protection from electric arcs within the module due to cell breaks or cell interconnection breaks
- e energy yield**
 Bypassing the shaded areas of the module

HIGHEST FAILURE RATE IN PV-MODULES IS THE DIODE.

Bypass diodes dominated the past decades

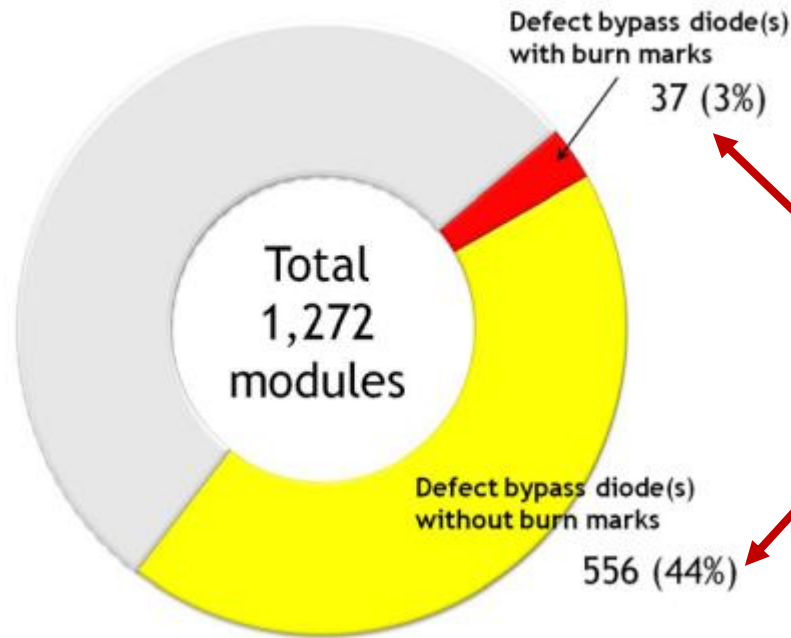

47% Standard Diode Failure Rate

A result of bypass diode check for 1272 PV modules. The diagram shows the number and percentage of PV modules with one or more defective bypass diodes. The PV modules have been in the field for about four years !

High risk of 3,75 billions defective diodes

Source : [Herrmann09] W. Herrmann, W. Wiesner, W. Vaaßen, Hot Spot Investigations on PV Modules - new Concepts for a Test Standard and Consequences for Module Design with Respect to Bypass Diodes, Proc. 26th PVSC (IEEE, Anaheim, CA, USA, 1997), pp. 1129-1132 88 [Kato02] K. Kato, "PVResQ!": A Research Activity on Reliability of PV System from an user's viewpoint in Japan, Proc. Optics + Photonics 8112 (SPIE, San Diego, California, USA, 2011), 811219

WHAT ARE THE PROBLEMS OF BYPASS DIODES ?

Bypass diodes dominated the past decades

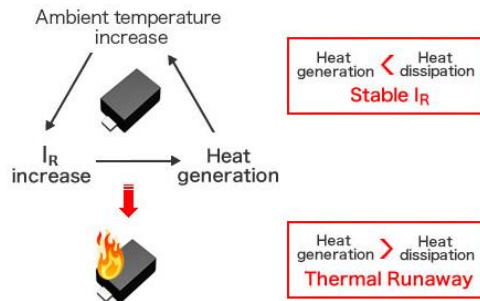
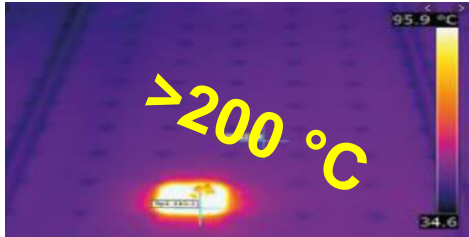

- e** In case of bypassing very strong heating up (>200°C) due to the high forward voltage drop on shottky diodes from 0,3..0,7 V and the high currents in the new generation of high power modules (>11A)

$$P_{\text{loss}} = U_{\text{fwd}} \times I_{\text{bypass}} \rightarrow 3,3 \text{ .. } 7,7 \text{ Watt losses}$$

- e** accelerated aging of all bypass diode adjacent materials (Arrhenius-equation)

- e** very high sensitivity against surges especially with Shottky - diodes

- e** Thermal instability due to high reverse currents in shottky diodes (Thermal Runaway)

Increase of JBox Temperature from 25° - 70° C -> leads to **35 times** higher leakage current

If the generated heat exceeds the amount dissipated, this can lead to additional increasing heat generation and leakage current and eventually result in damage.

TEMPERATURE CYCLES CAUSES THERMAL STRESS.

Bypass diodes dominated the past decades

- e Temperature cycles have strong influence on the service life of components
- e Different temperature coefficients lead to mechanical stress within the components.

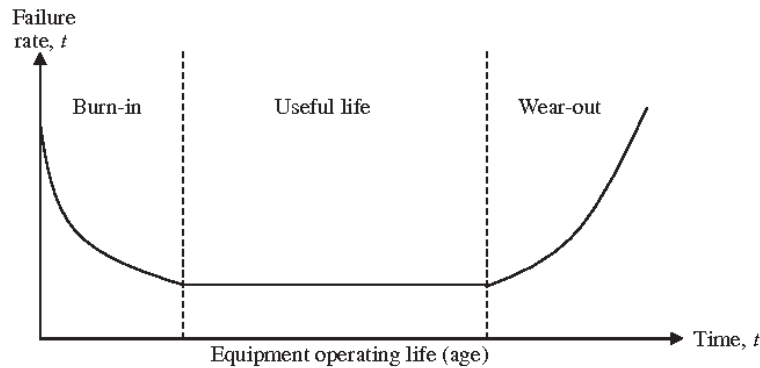

- e Shading situation on a daily cycle is acceptable
- e Periodic shadowing with low frequency, as they are can be caused by the shadow of a wind turbine associated shows dramatically increased failure rates and very high JBox Temperatures.

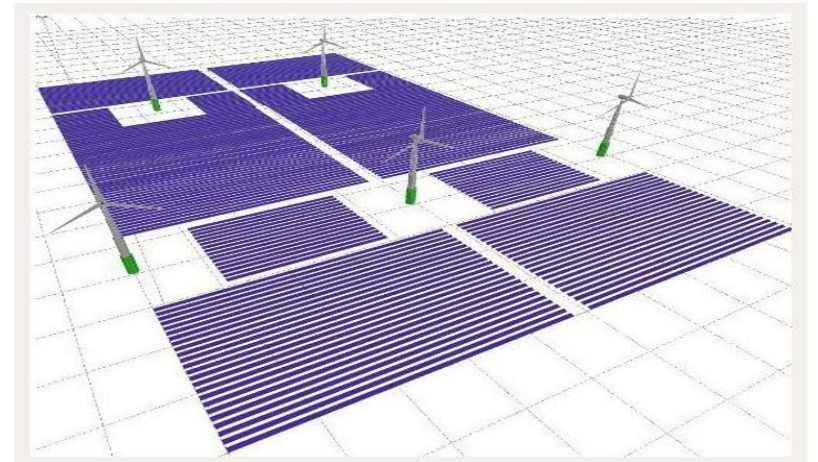

Source: <http://www.erneuerbareenergien.de/kaum-verschattungdurch-windtuerme/150/436/62186/>

Source: <http://www.uni-kassel.de/upress/online/frei/978-3-89958-718-0.volltext.frei.pdf> (page 23 ff)

e.ISP

Integrated Shadow Protection

The **only** module in the world
with integrated control
electronics.



e.ISP – Technology, half cells and 12 bus bars. Ask for more.

Gamechanging Technology of the future available today

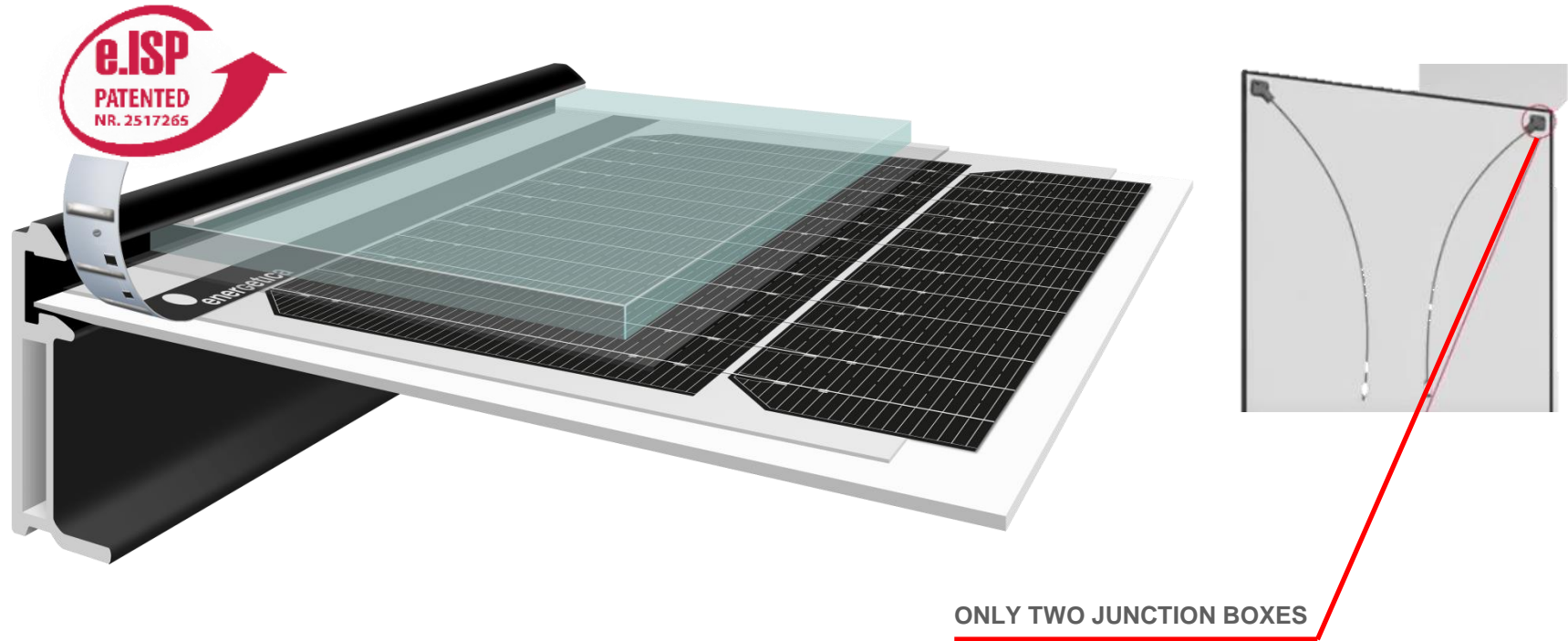



Energetica Integrated Shadow Protection (e.ISP) - the intelligent, highly efficient control electronics that are integrated into the PV module via a printed circuit board.

The solution for constantly optimized efficiency in shading.

ADVANTAGES OF e.ISP-TECHNOLOGY

Reaching for more

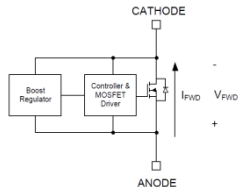
	p-n-Diode	Schottky-Diode	e.ISP - Technology
Principle			
Maximum Reverse Voltage	200 – 1000 V	40 – 70 V	30 – 40 V
Max. average forward on - voltage @ $T_J = 125\text{ }^\circ\text{C}$, $I_D = 10\text{ A}$	0,5 - > 1,25 V	0,3 - 0,7 V	< 0,05 V
Reverse current @ $T_J = 125\text{ }^\circ\text{C}$, $U_R = 15\text{ V}$	μA	mA - A	nA - μA
Surge- und ESD-robustness	uni-directional	uni-directional	bi-directional
power loss / module @ 10A	15 – 36 Watt	15 - 21 Watt	1,5 Watt

10 times better than conventional Bypass Diodes

ADDED VALUE FOR THE CUSTOMER

Step into the future with integrated intelligent electronics

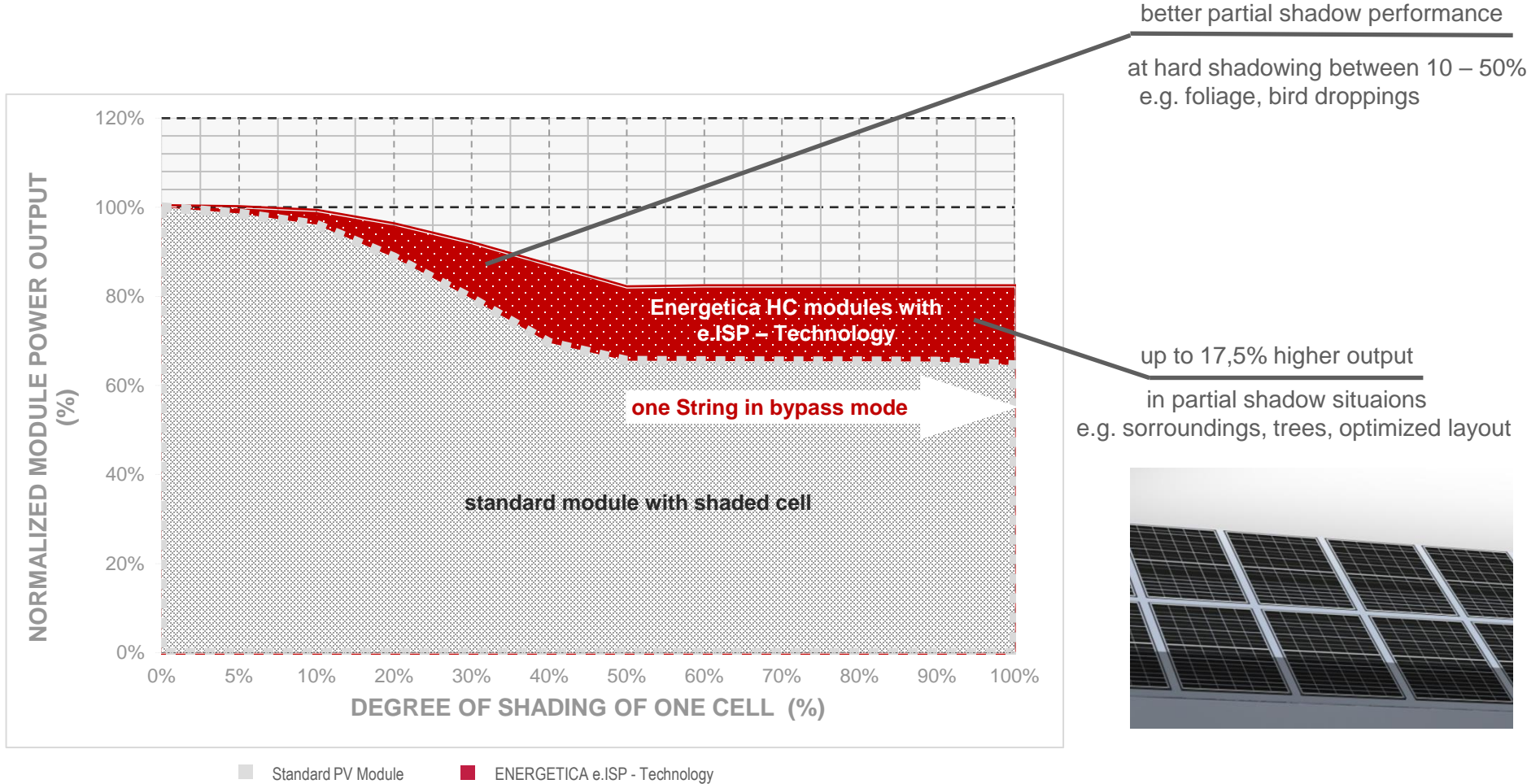

better partial shadow performance
 at hard shading between 10 – 50%
 e.g. foliage, bird droppings

up to 17,5% higher output
 in partial shadow situations
 e.g. surroundings, trees, optimized layout

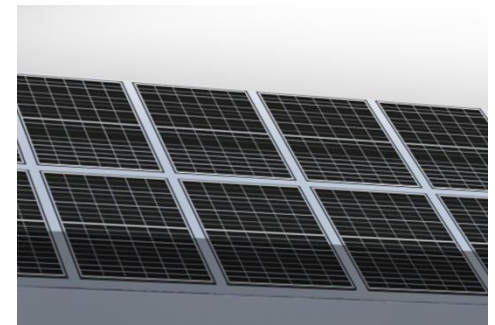

CONVENTIONAL TECHNOLOGY

No potential for further efficiency increase – Standard has reached its limits

conventional full cell module
0% power generation

but consumption on each module

Less safety.
Shorter lifespan.
High Temperatures.
Reduced performance.

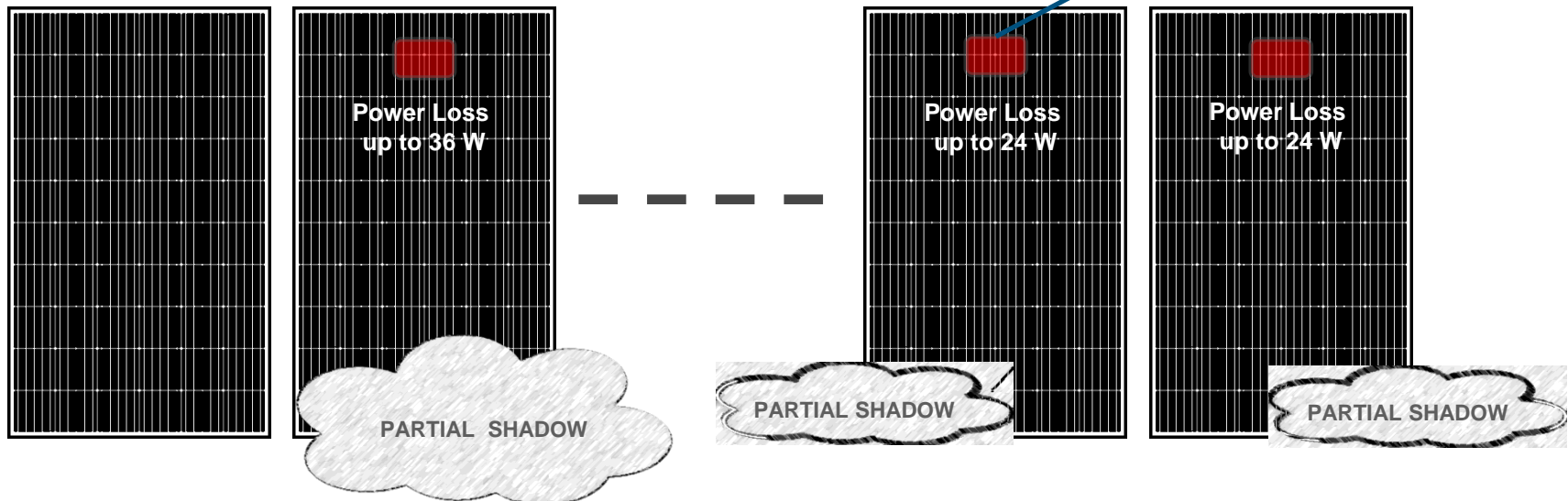

ADDED VALUE FOR THE CUSTOMER

Step into the future with integrated intelligent electronics



**Energetica e.ISP-Technology
up to 67% more power generation**

**Longer lifespan.
Higher performance.
Cooler Module Temperatures.**

NO consumption !

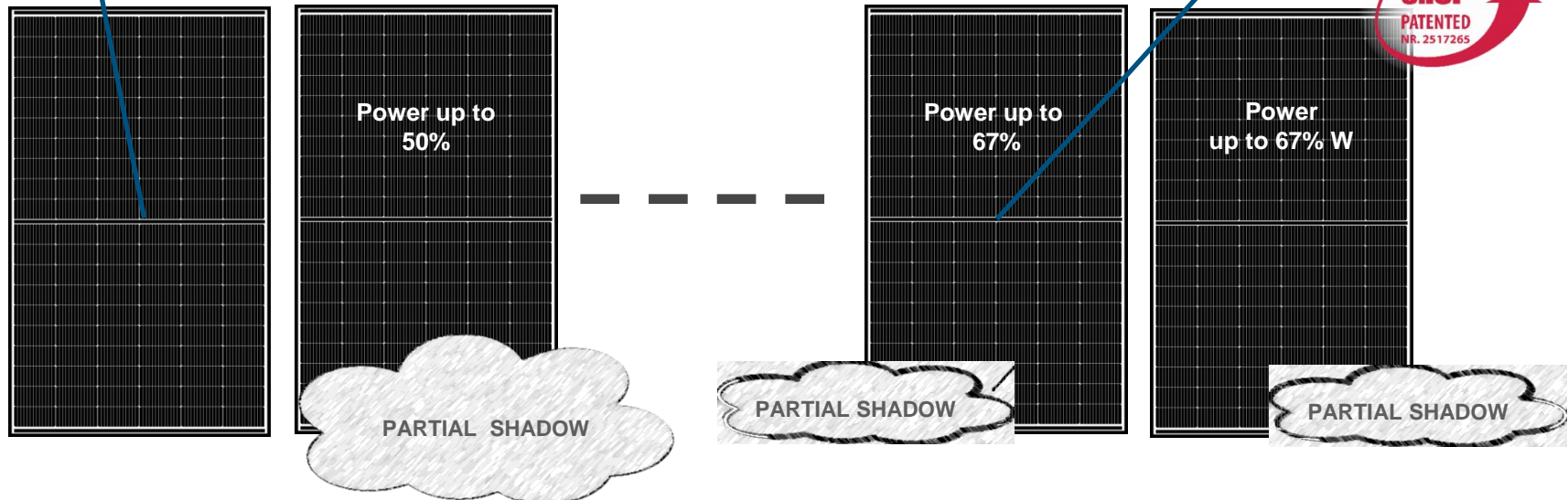

UP TO 50 DEGREES COOLER.

e.ISP Technology reduces dramatically the temperature impact on solar modules

e.ISP Integrated Shadow Management

No increase on panel temperature.
 Less aging of materials.
 Longer lifespan.
 Higher Performance.

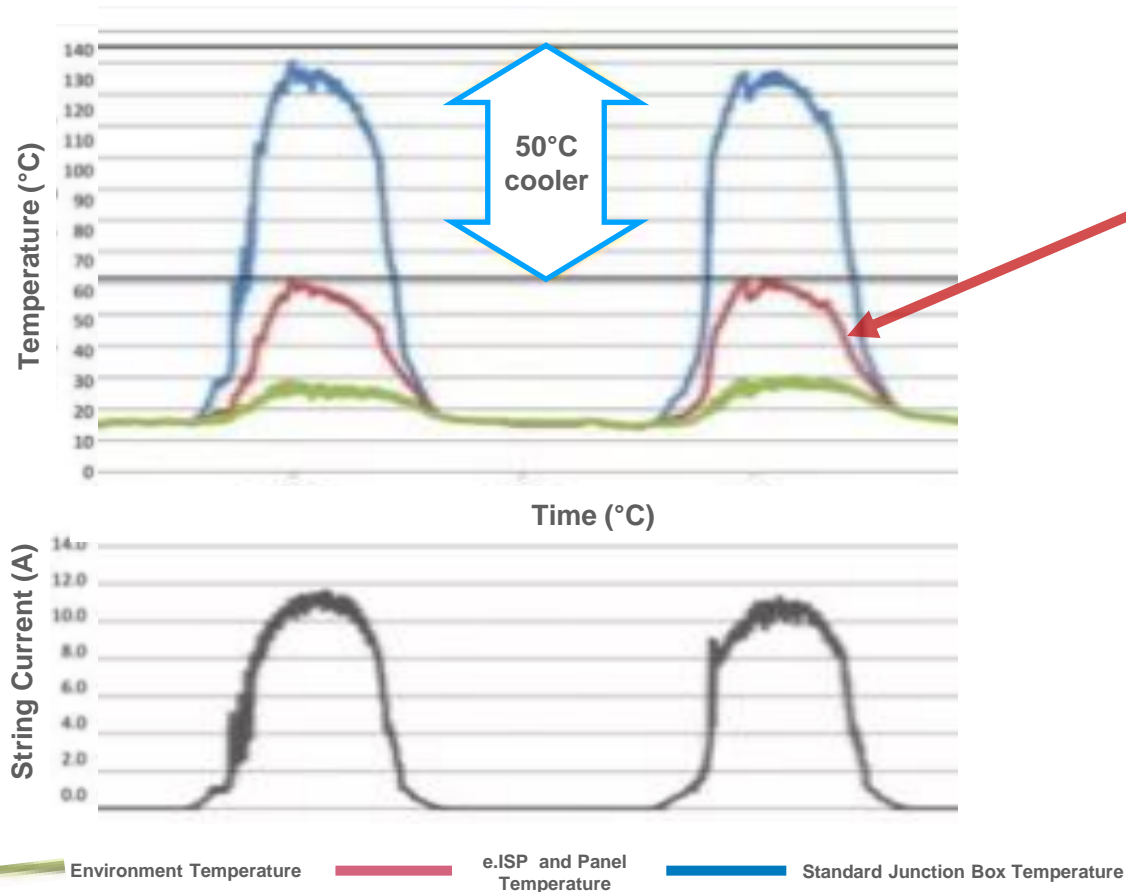

25 YEARS LIFETIME TESTED BY 3rd PARTY INSTITUTE

Due to decreases material aging and lower temperatures

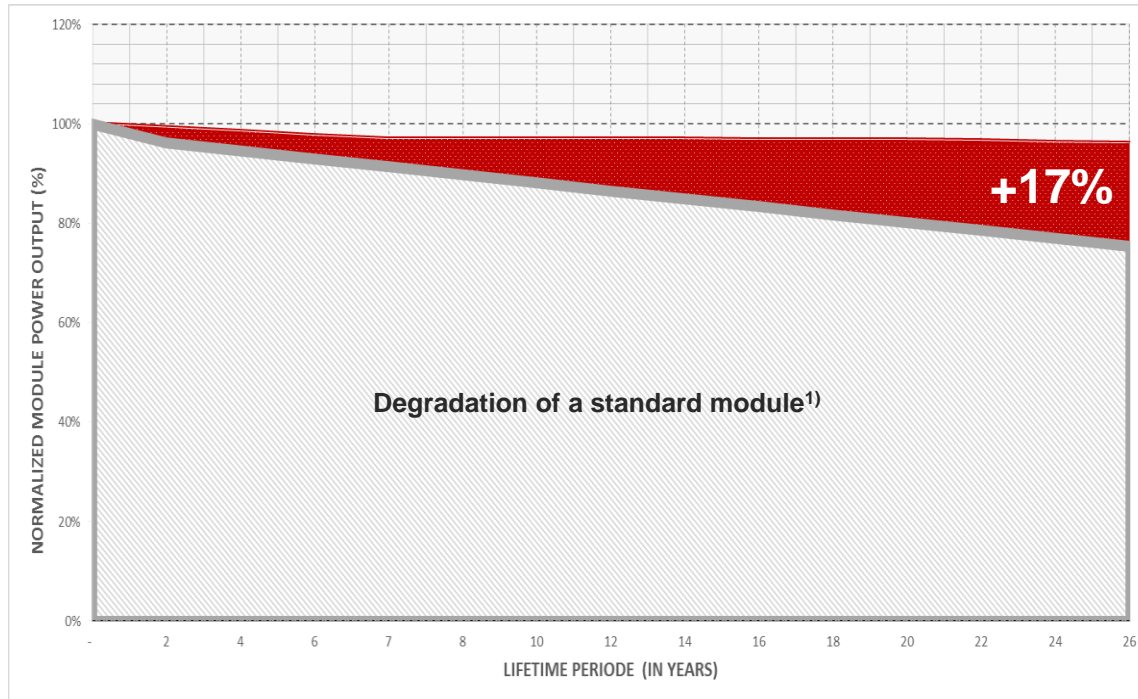

Longer lifespan.
Higher performance.
Significantly Lower module temperatures.

+17%

Lifetime Test done at ::



¹⁾ Source: NREL, Photovoltaic Degradation Rates – An Analytical Review, Dirk C. Jordan and Sarah R. Kurtz, June 2012



WE BRING THE FUTURE TODAY.

HIGHEST POWER. SMART INTEGRATED ELECTRONICS.

TECHNOLOGICAL LEADERSHIP.

the heart and soul of an Energetica module



Weather-resistant QR barcode with exact measured output, serial number and module type



safe storage in any environment
safe transport (no transport-induced micro-cracks)
safe handling (horizontally positioned means easy to be handled and carried while manual unloading)
wrapping material made of biodegradable material

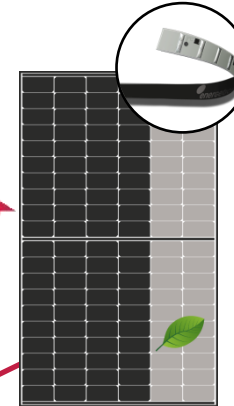
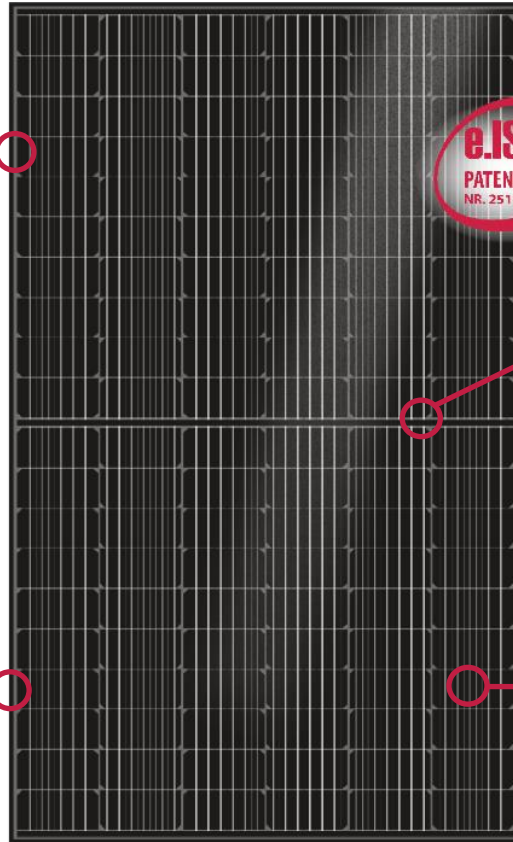

Energetica Integrated Shadow Protection (e.ISP) intelligent, highly efficient Control electronics integrated in the PV module through a printed circuit board. The ultimate solution for constant optimized efficiency in case of shadows



12BB solar cell is 0.448% more efficient than 5BB solar cell and has 8.044w more power
shortens the transmission distance for electrons: reduced distance leads to less electrical losses and 2% power increase



Wires with circular cross-sections: increase light absorption in the cell from different angles

ROADMAP to THE FUTURE

European technology leader on the path to innovation

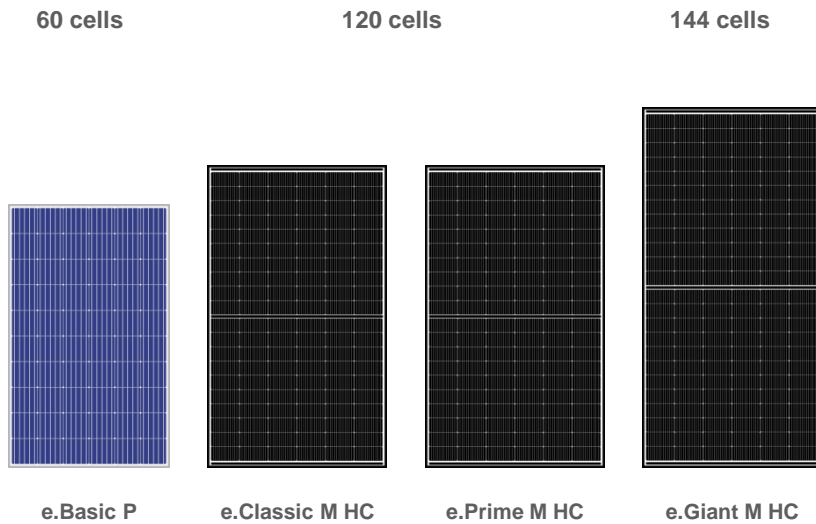

Increased performance per square meter.

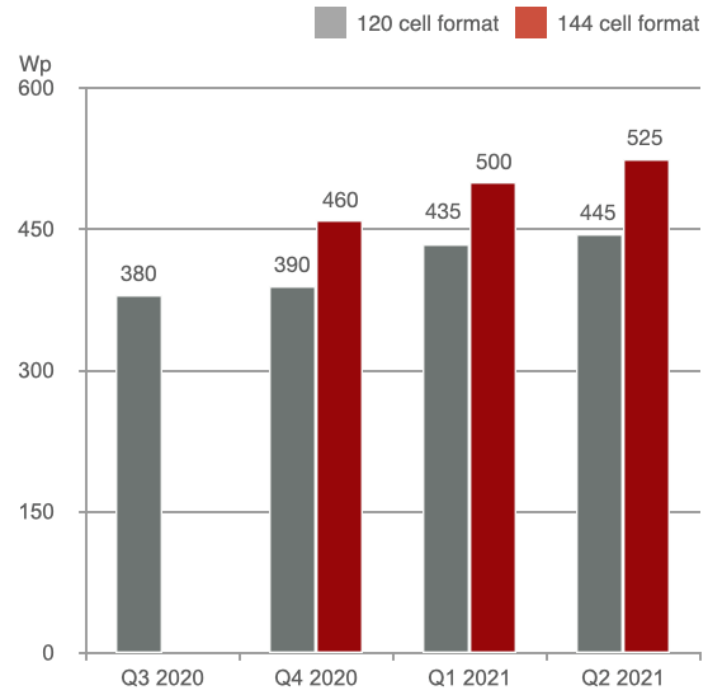

Pushing up the limits!

PERFORMANCE ELECTRIFIED.

The Energetica product family

e.Classic

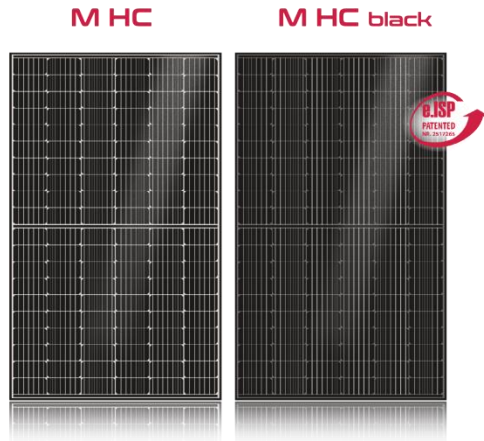

Performance booster

up to 390 Wp
from Q1 2021 up to 420 Wp

e.Giant

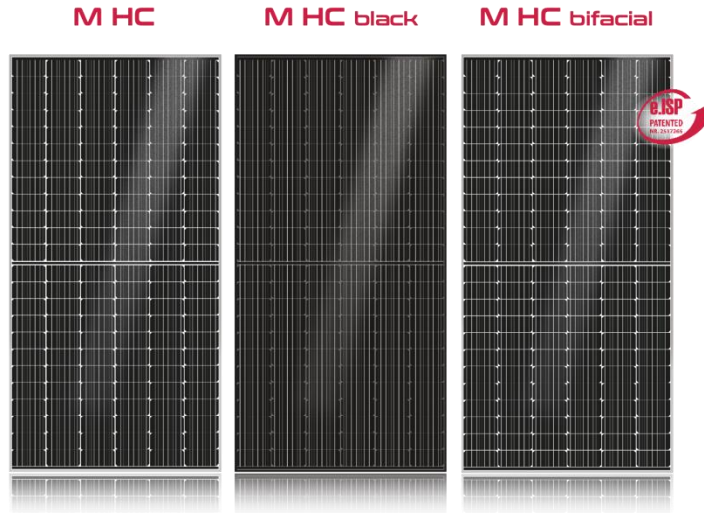

Power booster

up to 470 Wp
from Q1 2021 up to 510 Wp

e.Prime

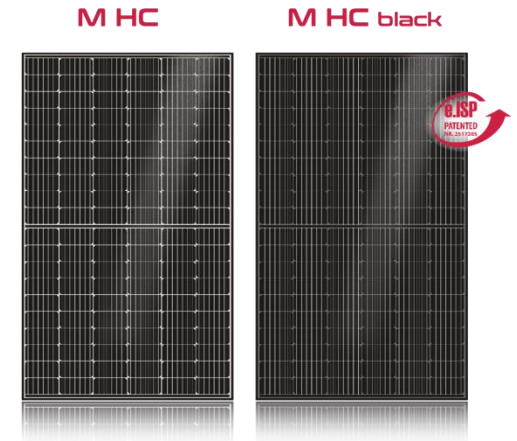

Heavy load runner

8000 Pa
up to 390 Wp

#BePartOfTheChange

energetica
PHOTOVOLTAIC INDUSTRIES



Simply smarter in modules.

energetica-pv.com

The **only** module in the world
with integrated control electronics.